

**Gate Lock Fitting**  
**Instructions**

1. When fitting the post that is going to be fitted with the lock it is best to have the large cavity facing the lock side. Determine the height for the latch and then drill the holes as shown below.

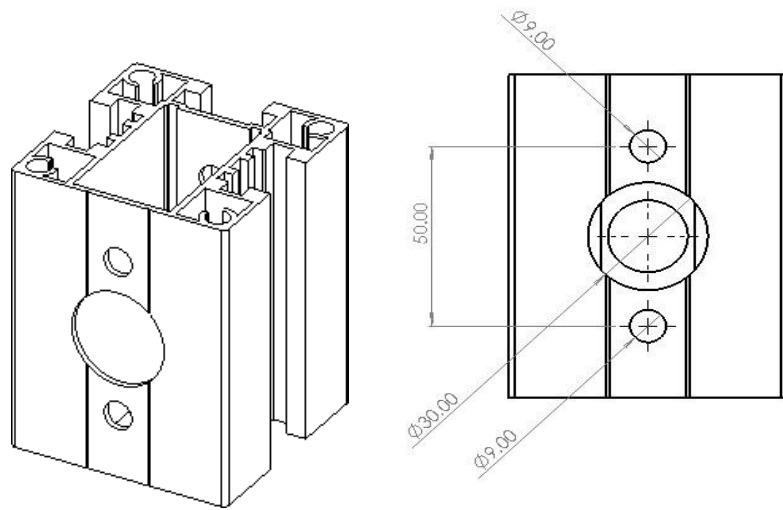

2. Now on the other side drill the holes shown below ensuring that the three centre holes line up with the holes at the front. Ensure that the Dia 3.5 holes go through 2 x wall sections to allow for the 32mm long self-tapping screws.

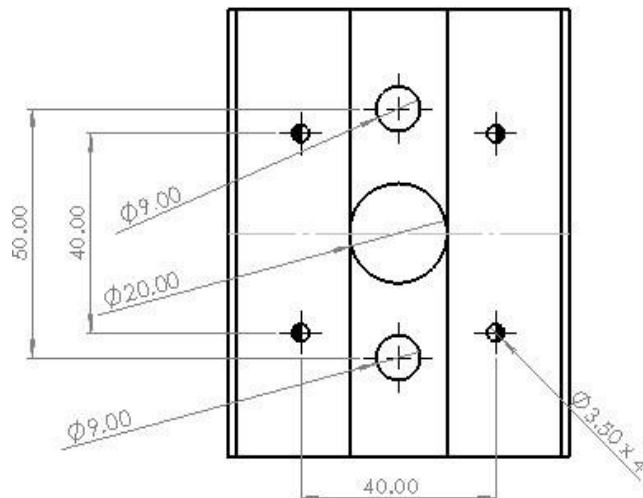

3. Now assemble the lock as shown using the M5 x 50 Pan Head Screws supplied

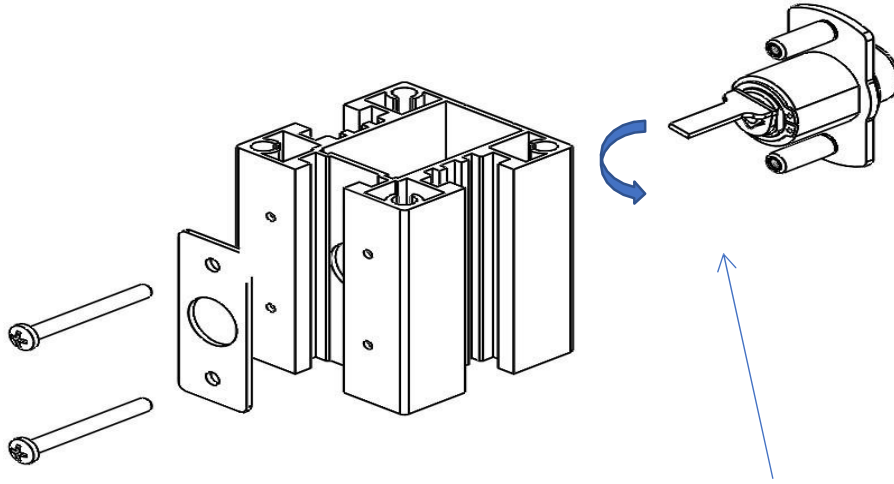

Tab to be at the bottom for non-locking

4. Now fit the latch using 4 of the No8 x 32 self-tapping screws provided.

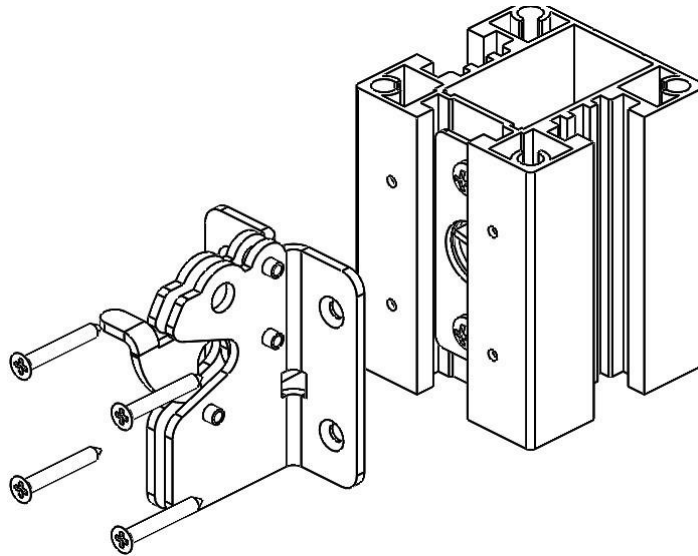

5. Cut the post inserts to suit, which will hide the internal channel section of the post.

6. Now fit the striker pilot drilling the holes Dia 3.5 through 2 sections of the gate frame as shown below. Ensure that the striker is located as shown.

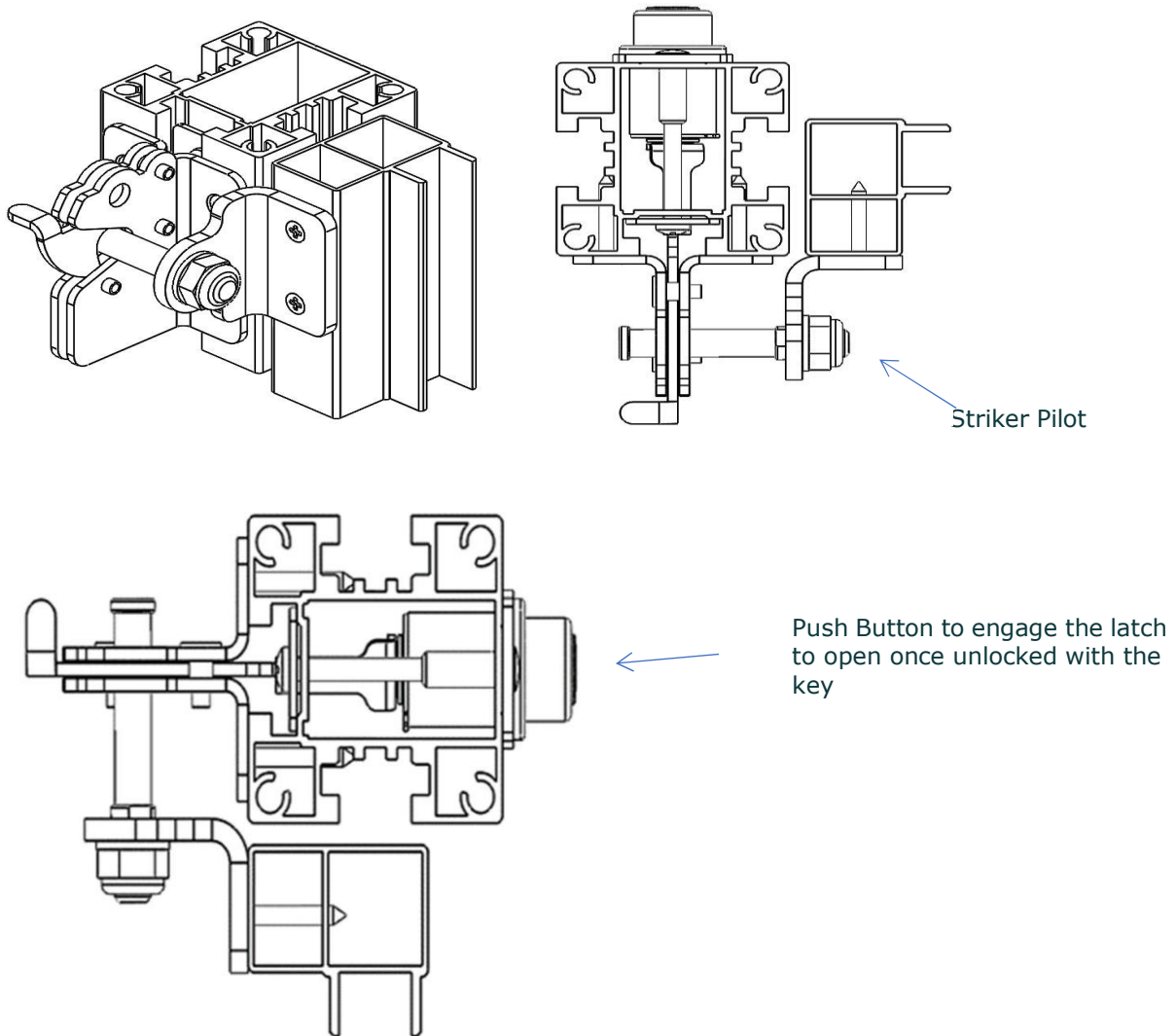

**Note:**

The lock can be left in the open or closed position depending on the direction that the key has been turned. When in the open position, pressing the push button will open the latch. When in the locked position, the button can still be pressed but the latch will remain closed.

For extra security the latch can be locked from the inside by placing a suitable padlock through the hole in the latch.